

**GMX Disc Brake Caliper - Pneumatically Applied, Spring Released**

Nominal Dimensions given  
For caliper dimensions see DS2600

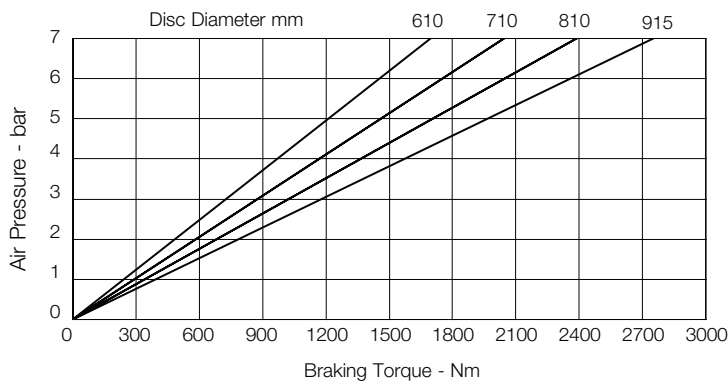
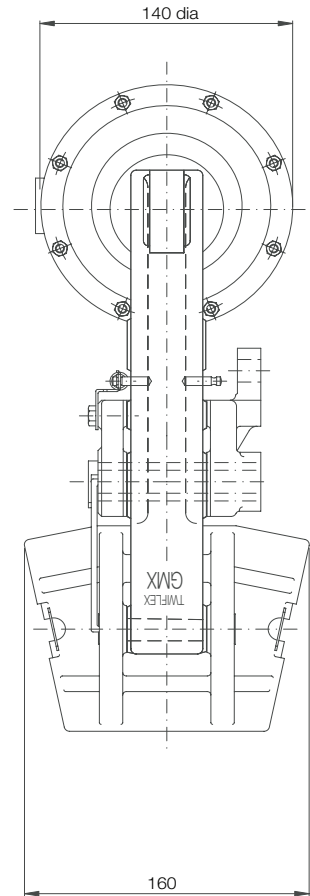
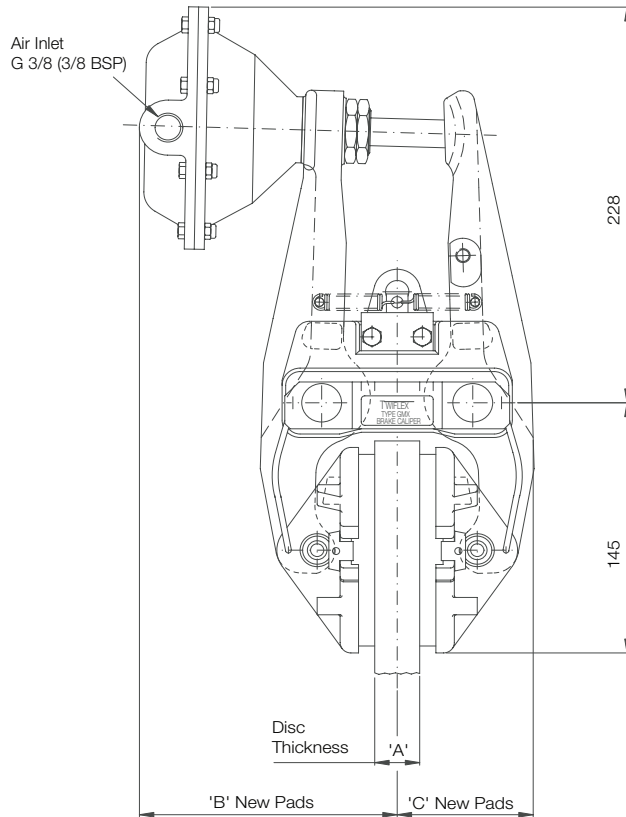

Dimensions in mm			
Caliper	A	B	C
GMX 25	25.4	148.5	76
GMX 30	30	150	77.5
GMX 40	40	153.5	81

Weight (caliper and thruster) - 10.54kg  
(thruster only) - 1.32kg

Volume displacement of thruster at full stroke is 300ml.

**Maximum pressure 7 bar**

**Maximum Braking Force - 6.9kN @ 7 bar**

The ratings shown on the above graph are based on fully bedded and conditioned brake pads with nominal friction coefficient  $\mu=0.4$ .

For bedding-in and conditioning procedures see Publication M1060.

Braking Force is defined as the Tangential Force acting on the brake disc at the Effective Disc Radius.

Braking Torque (Nm) = Braking Force (N) x Effective Disc Radius (m) where Effective Disc Radius = Actual Disc Radius - 0.06.

Twiflex Disc Brakes must be used with Twiflex asbestos free brake pads. The use of any other brake pads will invalidate the warranty. Twiflex Limited reserves the right to modify or change the design without prior notice.

# GMX Disc Brake Caliper - Pneumatically Applied, Spring Released

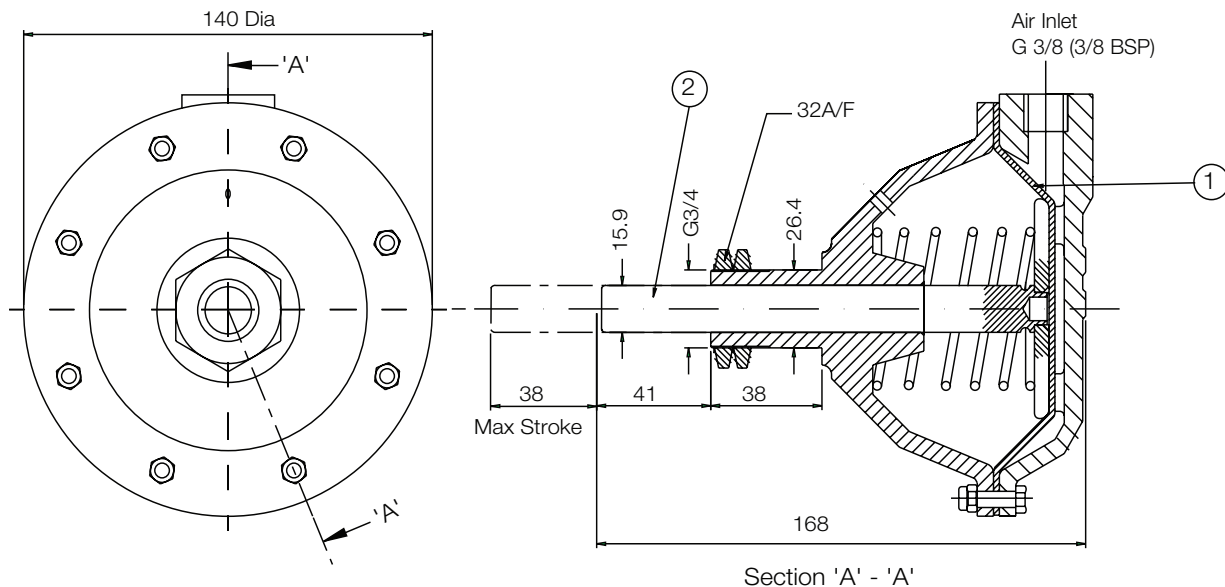

This range of pneumatically operated brakes uses dry and filtered compressed air at pressures up to 7 bar. Pneumatic brakes require a control valve which may be operated either manually, or by pneumatic or electrical signal.

Should it become necessary to replace a diaphragm, ensure air supply is disconnected, remove the M5 bolts and the rear cap of the thruster. Remove the worn diaphragm; clean-up the contacting surfaces and re-assemble with the new diaphragm and bolts in position. (Tightening Torque 5.7Nm)

## Thruster Part Number 7200056

Available Spares		
Item	Component	Part No.
1	Diaphragm Kit	7902801
2	Piston Rod Assembly	7200493

## Thruster Fitment

1. Offer thruster to caliper making sure that both lock nuts are removed before placing push rod through caliper arm.
2. Fit lock nuts over the push rod and locate its end within the slot of the other arm.
3. Tighten one lock nut to 50-60 Nm then tighten the second nut against the first.

