

**“MP” Electro Hydraulic Power Units**

**1. General Description**

This data sheet describes the Modular Power (MP) Electro Hydraulic Power Units, which have been designed to provide an advanced and flexible means of brake control.

The MP unit is particularly useful when the installation requires the operation and control of two or more independent brake circuits, dual braking, or where there is a special requirement for meeting a particular industrial specification. Typical examples where the system is already in use include larger scale conveyors in Venezuela, ship to shore cranes in Felixstowe and wind turbines in Scotland. On a smaller scale, the system is used on escalators installed in the London Underground, which include both service and emergency brakes.

The MP unit essentially consists of a base module (para 2.2.1) onto which can be fitted a number of ‘slices’ to provide varying degrees of hydraulic control. Four standard circuits ranging from basic on / off control to full closed loop control can be provided (para 2.3).

In addition, a number of auxiliary options are available (para 2.7) as well as optional slices for special requirements (para 2.8).

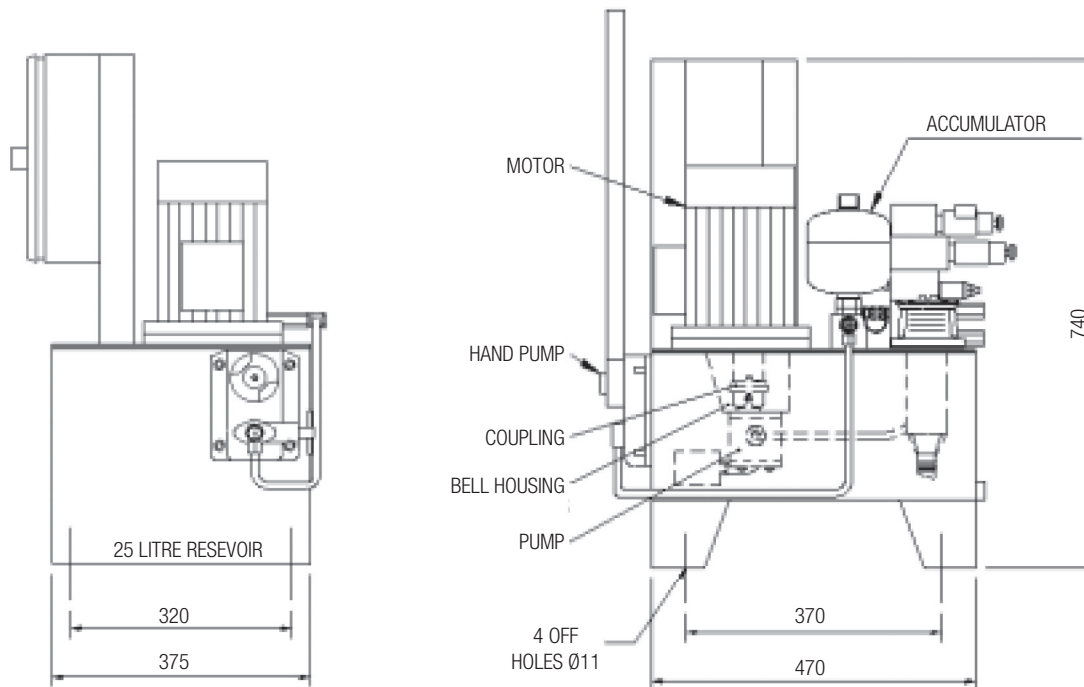

**Typical Arrangement of the Modular Hydraulic Power Unit**

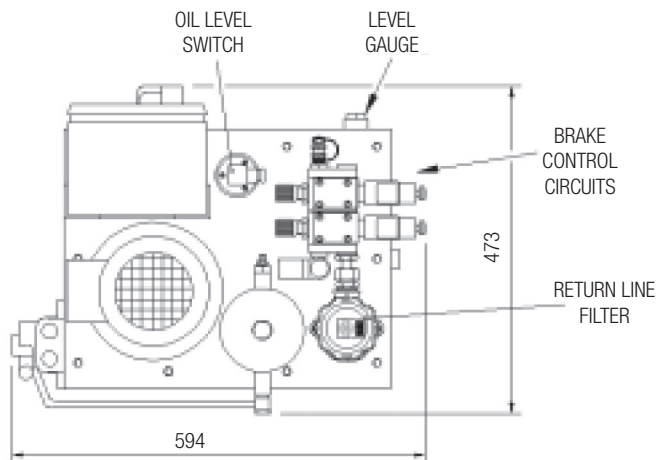

Note: If you require a circuit option which is not covered in this document, please contact Twiflex to discuss your particular requirements

All Twiflex power units are pre-set for the intended braking systems. Hydraulic test certificates are available upon request.

# “MP” Electro Hydraulic Power Units

## 2. Ordering Your Modular Power Unit

Selecting a suitable hydraulic power pack to operate a range of disc brakes, can seem at first glance a daunting task. The following pages contain a guide for both the novice and the expert, giving a stepby- step process for selecting an ‘MP’ unit, and starts by giving an example of how to order.

### 2.1 Ordering Example

**Example:** An open-loop control system with soft braking is required to bring a conveyor to rest over a 12 second period irrespective of load. Two VCS calipers have been selected for the emergency brakes and one off MXSH caliper for the service brakes. Power supply available is 380V at 50Hz with a solenoid voltage of 24V DC. Control box, additional pressure gauge and hand pump is also required. A pressure reducing station is also required for the MXSH.

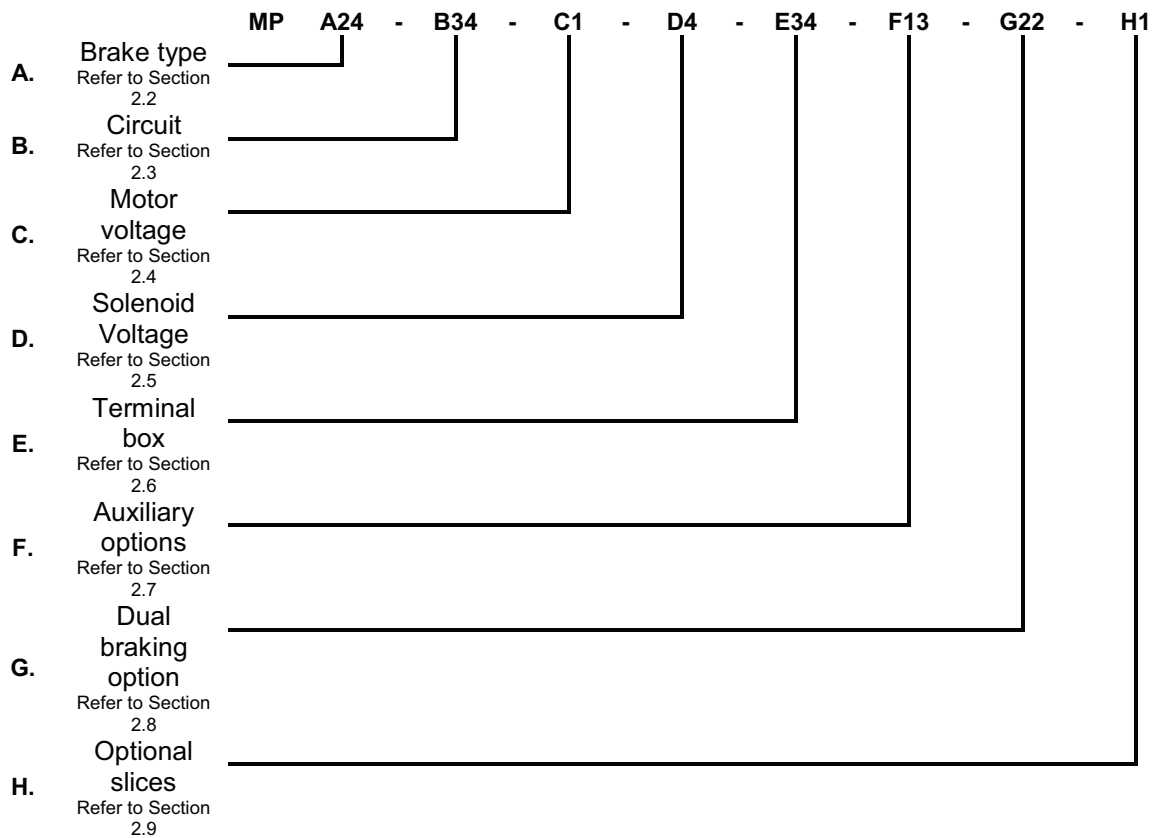

### Example 2:

A simple on / off braking system with soft braking is required to bring a hoist to rest. Two MXSH have been selected for the service brakes. The brake system must have a complete override switch to bring all the brakes on. Power supply and solenoid voltage is 230V at 50Hz. A terminal box, (no motor contactor), additional pressure gauge and hand pump and oil level switch are required.

**The order code will be:                   MP - A22 - B12 - C03 - D01 - E12 - F134 - G00 - H02**

# “MP” Electro Hydraulic Power Units

## 2.2 Standard Brake Range

The table below lists the Twiflex range of spring applied – hydraulically released calipers, which are suitable for use with ‘MP’ units. If direct acting calipers are to be controlled, please consult Twiflex.

| Order Code | Caliper / Thruster Assembly | Max Thruster Force (kN) | Stroke (mm) / Release Pressure (bar) / Full Retraction Pressure (bar) | Base Model BM1, BM2 or BM3 |
|------------|-----------------------------|-------------------------|---|----------------------------|
| A01        | (MS,MR,MX,GMX) L            | 4.4                     | 4 / 40 / 50   | BM1                        |
| A02        | (MX,GMX) XSH/S              | 7.5                     | 6 / 54 / 65   | BM1                        |
| A03        | GMR SH(S)                   | 15                      | 40 / 120 / 150  | BM1                        |
| A04        | VCS                         | 62                      | 14 / 118 / 138  | BM2                        |
| A05        | VKSD                        | 148                     | 28 / 124 / 138  | BM3                        |
| A06        | VS                          | 230                     | 32 / 155 / 180  | BM3                        |
| A07        | VMS                         | 625                     | 77 / 135 / 160  | BM3                        |

NOTE: When selecting the brake caliper to be controlled, ensure that the total number of calipers on a single circuit is indicated before the order reference number.

Example: 2 off MXSH to be controlled, order reference code to be used is A22

### 2.2.1 Base Module

The Modular Power units are based on common Base Modules, which are designated BM1, BM2 and BM3 as shown in table below. The selection is made according to the brakes specified, and is made by Twiflex, unless the customer specifically states a preference.

Table in 2.2 indicates which Base Module would be selected for the various calipers, however, this selection is based on only one caliper in the circuit. For control of more than one caliper or for dual circuit braking, a larger base module may be appropriate. Contact Twiflex for more information on this type of installation.

| Base Module | Motor Rating | Pump Rating |
|-------------|--------------|-------------|
| BM1         | 0.55kW       | 1.5 l/min   |
| BM2         | 1.1kW        | 3.0 l/min   |
| BM3         | 1.5kW        | 4.5 l/min   |

The Base Module consists of an electric motor, coupled to a pump, mounted vertically on a 25 litre steel reservoir. Flow from the pump passes into the Main Manifold Block (CETOP Type (AG Din 24340)) incorporating a Pressure Switch, Check Valve and Test Point Connector. The standard unit includes a 0.7 litre Accumulator and Relief Valve, although larger Accumulator's may be fitted for one shot brake release. (See section 2.7)

The Base Module also houses a Filler Breather, Bell Housing, Coupling, Suction Strainer, Sight Glass and other auxiliary optional extras (see section 2.7)

# “MP” Electro Hydraulic Power Units

## 2.3 Hydraulic Circuit

Twiflex have developed a range of four standard braking systems, SC1 to SC4. Based on the company’s 50 years in the braking industry, these circuits are deemed to cover the majority of controlled braking applications, which will be experienced.

Each standard circuit is described in more detail below. Note that all the systems can be customised with a selection of auxiliary options described in section 2.7.

| Circuit Type | Single Circuit Standard | Single Circuit Controlled | Dual Circuit Standard | Dual Circuit Controlled |
|--------------|-------------------------|---------------------------|-----------------------|-------------------------|
| SC1          | B11                     | B12                       | B13                   | B14                     |
| SC2          | B21                     | B22                       | B23                   | B24                     |
| SC3          | No Option               | B32                       | No Option             | B34                     |
| SC4          | No Option               | B42                       | No Option             | B44                     |

### SC1 – Basic System

This is a Basic system designed for simple and direct operation of Brakes. A single solenoid 3/2 valve is used to switch the supply between Brake On and Brake Full Retraction, giving a fast acting system in both operations.

The circuit shown has been upgraded with an additional slice to facilitate a fast approach soft braking system. This enables the rate at which the brake is applied to be controlled, and incorporates a fast approach element to ensure the pads make immediate contact with the disc.

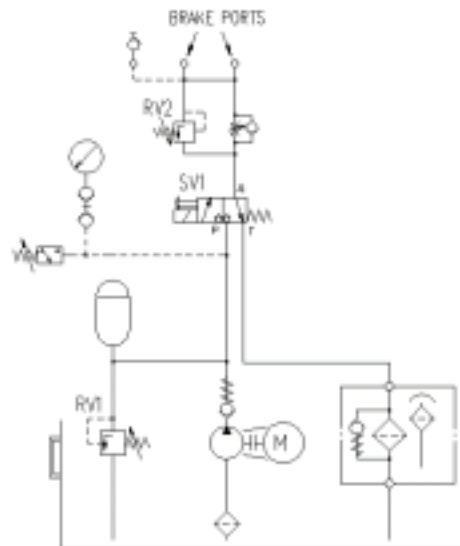

### SC2 – High Flow System

This is a High Flow system designed for simple and direct operation of brakes, with no additional control requirements, but giving a higher flow rate through the system by the use of two solenoid valves. The higher flow rate enables very rapid brake operation of either single or multiple brake arrangements and shorter brake retraction times.

The circuit shown has been upgraded with an additional slice to facilitate a fast approach, soft braking system. This enables the rate at which the brake is applied to be controlled and incorporates a fast approach element to ensure the pads make immediate contact with the disc.

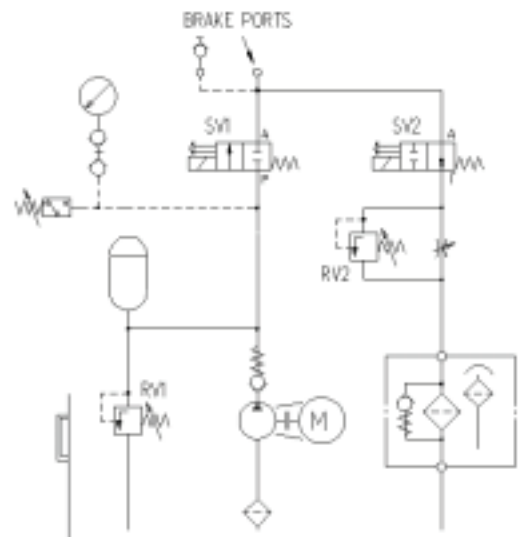

# “MP” Electro Hydraulic Power Units

## SC3 – Open Loop Control

The SC3 is an Open Loop control system intended for control of the braking force, in conjunction with a Brake Controller. Typically this can be applied to conveyors and wind turbines where the rate of deceleration must be regulated due to safety or mechanical restrictions.

The SC3 uses two 2/2 valves; the normally shut “Brake off” Valve (SV1) and hence the default condition of the brake is on. Energising both of these valves brings the brake off. Applying the Brake in a controlled manner is achieved by closure of the ‘Off’ Brake Valve (SV1), before opening the ‘On’ Brake Valve (SV2), with the use of an electronic valve delay module located in the terminal / control box.

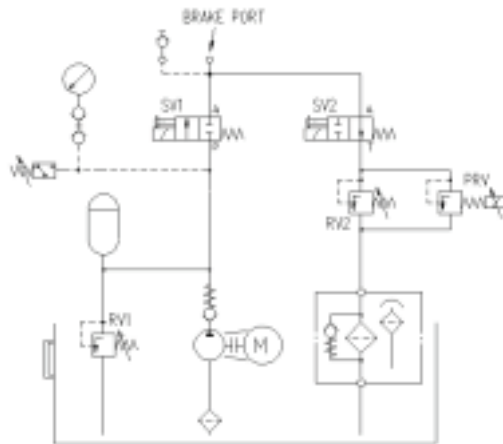

The Proportional Relief Valve (PRV) in the brake line to tank is used to reduce the back pressure in a controlled manner, but this would cause a slowing Brake operation during the approach phase. A ‘Fast Approach’ element is therefore included to ensure the brake pads make rapid contact with the disc.

The proportional control valve requires a 24V DC power supply to drive the amplifier (which is temperature compensated), and a demand signal between 0 - 8V is required which will determine the amount of pressure drop.

## SC4 – Closed Loop Control

The SC4 is an Closed Loop Control system intended for control of the braking force in conjunction with a Twiflex Brake Controller which uses a PLC driven Closed Loop Control with speed and / or load sensors. Typically this can be applied to mining hoist, ladle cranes and applications where personnel transportation is involved, where the rate of deceleration must be regulated due to safety or mechanical restrictions

System SC4 is essentially the same as the SC3, where two 2/2 valves are used, the normally shut “Brake off” Valve (SV1) and the normally open “Brake on” Valve (SV2), hence the default condition of the brake is on. Energising both of these valves brings the brake off. Applying the Brake in a controlled manner is achieved by closure of the ‘Off’ Brake Valve (SV1) before opening the ‘On’ Brake Valve (SV2), with the use of an electronic valve delay module located in the terminal / control box.

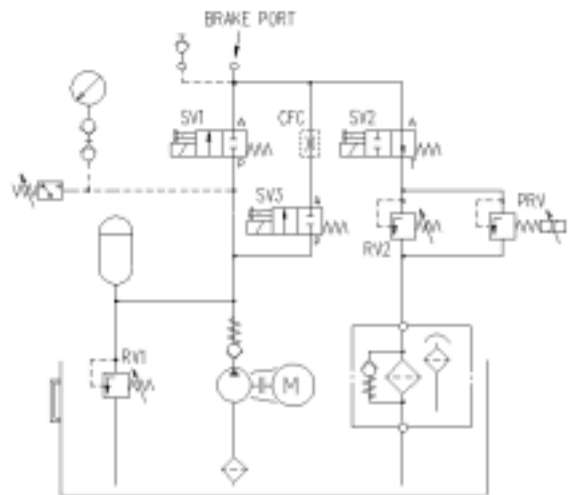

Unlike the open loop system, the SC4 controller can reduce the Braking Force, (i.e. increase the back pressure). This is achieved with the use of a Compensated Flow Control Valve in the line from Valve SV3 to the brake, which will allow constant flow. With both valves open the PRV can adjust the retraction pressure to give both increasing and reducing braking forces, by regulating the flow.

The Proportional Relief Valve in the Brake Line to Tank is used to reduce the back pressure in a controlled manner. This also causes a slowing of Brake operation during the approach phase. A ‘Fast Approach’ element is therefore included to ensure the brake pads make immediate contact with the disc.

The optional control box contains the controller, which will generate the demand signal between 0 - 8V to drive the proportional control valve, and also contain a 24V DC power supply to drive the amplifier.

# “MP” Electro Hydraulic Power Units

## 2.4 Motor Connection Voltage

Connection voltages for the motor have been given the following code:

| Order Code | Phase | Voltage V | Hertz Hz |
|------------|-------|-----------|----------|
| <b>C1</b>  | 3     | 380 - 420 | 50       |
| <b>C2</b>  | 3     | 440 - 460 | 60       |
| <b>C3</b>  | 1     | 220 - 240 | 50       |
| <b>C4</b>  | 1     | 220       | 60       |

## 2.5 Auxiliary Connection Voltage

Connection voltages for the pressure switch, solenoid valves and other optional extras have been given the following codes:

| Order Code | Phase | Voltage   | Hertz |
|------------|-------|-----------|-------|
| <b>D1</b>  | 1     | 220 - 240 | 50    |
| <b>D2</b>  | 1     | 220       | 60    |
| <b>D3</b>  | 1     | 115       | 60    |
| <b>D4</b>  | DC    | 24        | DC    |

## 2.6 Electrical Terminal Box

The ‘MP’ units may be supplied with either a terminal box or control box, mounted to the top of the unit, see fig 1. The enclosures are constructed of steel and electrically protected to IP65.

Terminal box. This contains a terminal rack where all control and supply leads are terminated. As an option, a motor contactor may be installed which will also include fuses, switch gear, and thermal overload relay. The box is 300 x 200 x 160 (mm)

Control box. This option is only available with the SC3 and SC4 and contains in addition to the above, a 24V DC power supply unit for the proportional control valve, and in the case of SC4 a Twiflex controller for closed loop control braking. Please refer to Twiflex for this option. The box is 325 x 325 x 160 mm.

NOTE: SC3 and SC4 must have either a terminal box or a control box. If a terminal box is opted for, then Twiflex will assume the customer will be supplying the necessary control signals and / or a controller for the proportional relief valves.

NOTE: The terminal box does not include an auxiliary power supply. The customer is required to supply the correct voltages and any necessary control signals.

| Circuit Type | Terminal Box not Required | Standard Terminal Box | Terminal Box with Contactor | Control Box |
|--------------|---------------------------|-----------------------|-----------------------------|-------------|
| <b>SC1</b>   | E11                       | E12                   | E13                         | No option   |
| <b>SC2</b>   | E21                       | E22                   | E23                         | No option   |
| <b>SC3</b>   | No option                 | E32                   | E33                         | E34         |
| <b>SC4</b>   | No option                 | E42                   | E43                         | E44         |

# “MP” Electro Hydraulic Power Units

## 2.7 Auxiliary Options

---

Twiflex offer the a range of auxiliary equipment which can be fitted to any of the ‘MP’ units if required:  
Note: Multiple selections may be selected from this section.

- F1 Hand Pump with Check Valve**  
Useful when manual release of the calipers is required.
- F2 Heater (0.5 kW) with Integral Thermostat**  
Recommended when the environmental temperatures are below 10°C
- F3 Pressure Gauge (250 bar)**  
Necessary if any adjustments are to be made to any of the system settings, or if visual inspection of hydraulic pressure is required.
- F4 Oil Level Switch**  
Recommended if the ‘MP’ units are installed in a remote location, or if regular maintenance is not available.
- F5 One Shot Brake Release Accumulator**  
For use in a power failure when no hand pump is available. The accumulator has enough volume of pressurised oil to release the brakes fully.
- F6 Stainless Steel Tank**  
For use in extreme environmental conditions, e.g. for marine applications.
- F7 Pressure Switch**  
Additional pressure switch set by the customer.

## 2.8 Dual Circuit Brake

---

Dual braking is particularly useful when the installation requires the operation and control of two or more independent brake circuits of different brake / thruster types. For example service and emergency braking on cranes, escalators and conveyors. Refer to section 2.3.

Consultation with Twiflex is advised for this option

| Order Code    | Description  |
|---------------|--|
| <b>G0</b>     | No dual braking required   |
| <b>G1 ( )</b> | Dual braking required<br>Second brake circuit requires no control.<br>Enter the brake code as referred to in section 2.2 |
| <b>G2 ( )</b> | Dual braking required.<br>Second brake circuit requires the same specified control                                       |

## 2.9 Optional Slices

---

These offer a number of control options which are all ‘fail-safe’, meaning in the event of power loss, the brake will be fully applied. For more information on optional slices, contact Twiflex. Note: Multiple selections may be selected from this section.

- H1 Pressure Reducing Station**  
May be required where two different brake types are used
- H2 Emergency Braking**  
This gives ‘instant’ braking override on controlled systems
- H3 Accumulator Dump Slice**  
This used to discharge the accumulator pressure, e.g. for safety during maintenance

# “MP” Electro Hydraulic Power Units

---

## 3. Hydraulic Oil

---

- Operating Fluid:** DIN 51524 part 2, should be selected according to operating and ambient temperatures.
- Volume:** The effective volume of oil in the tank is 5.0 litres, with a usable volume of 0.7 litres.
- Viscosity:** Min viscosity 10 CSt, max viscosity 380 CSt. For frequent brake application, the optimum viscosity range should be 12 – 200 CSt. Max initial viscosity 800 CSt.
- Filtration:** When filling the tank, oil should be filtered through a filter with a minimum retention rate of  $\beta_{10} \geq 75$
- Temperature:** The LC Power pack is suitable for minimum start up temperatures of  $-15^{\circ}\text{C}$  and maximum operating temperatures of  $60^{\circ}\text{C}$ .
- 

## 4. Service and Maintenance

---

The ‘MP’ unit is essentially maintenance free. The oil level must be checked at appropriate intervals and the tank should be drained once a year, checked for contamination and the oil changed if necessary. The hydraulic pump should be returned to Twiflex if maintenance is necessary.

**Warning:** A high standard of cleanliness is essential when dealing with hydraulics. The operating temperature must not exceed  $80^{\circ}\text{C}$

---

## 5. Your Nearest Agent

---