

Tension Brakes/Air Cooled

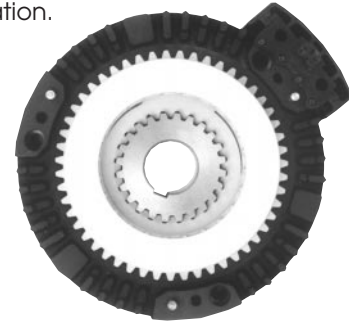

Mounting Ease

Three bolts mount the brake to the arm of the mill roll stand or machine frame and an optional pilot location makes fitting to both new and existing machines a simple operation.



Warner Electric's Wichita Mistral pneumatic tension brake is attuned to the needs of the corrugating market for which it was originally designed. It is also a versatile

product which is finding favor in additional tensioning applications. Wichita designers and engineers consulted extensively with mill roll stand manufacturers and users to offer a tension brake ideally

suited to the needs of this particular market. The result is a compact, high performance, versatile brake capable of handling the tensioning needs of the latest machine designs, as well as existing equipment. The Mistral paves the way for increasing line speeds by 5.4 feet/sec. from 810 feet/min. (or slower) to 1,140 feet/min.

Wear Indicator

A brake wear indicator, which is conveniently located for easy visual inspection, means no down time to check remaining friction material life.

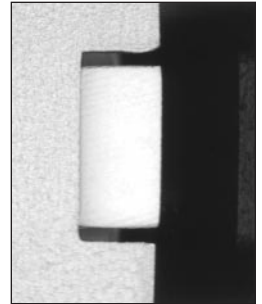

Easy Connection

Air and electrical connections are easily accessible for fast, simple installation and maintenance.

Compact Design, Modern Styling

Mistral brakes are compact at only 11.6" or 16.1" in diameter. Their size facilitates the pickup of small, part reels used in short batch runs. For automatic reel loading machines, Mistral offers optional infrared and speed sensor installation within the brake. And their modern, industrial styling enhances the appearance of any machine on which they are used.

Fine Tuning

Each brake may be specified with a varying number of pneumatic actuators, allowing precise selection of brake torque capacity for optimum tension control.

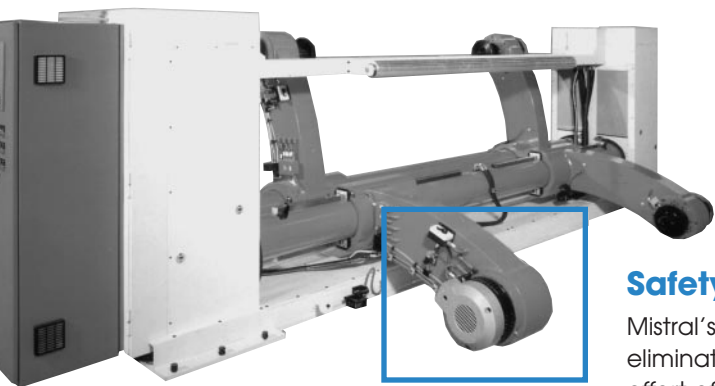
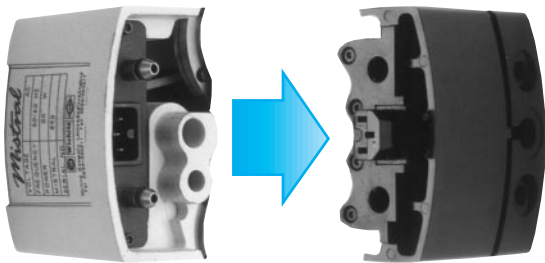

Safety

Mistral's integral guarding eliminates the cost and effort of installing external guards. Operator safety is further enhanced by automatic air and electric disconnects when the front cover is removed.

Front Cover Removal

By removing just three cap screws, the Mistral's front cover can be detached for easy and fast access to internal parts. Cover removal automatically disconnects both air and electricity.

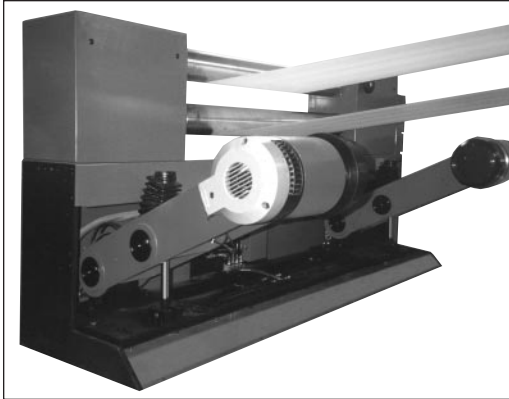

Integral Cooling

A rugged, high performance, low energy usage fan is housed within the brake for high heat dissipation — a must for increased productivity through controlled tension at many roll speeds.

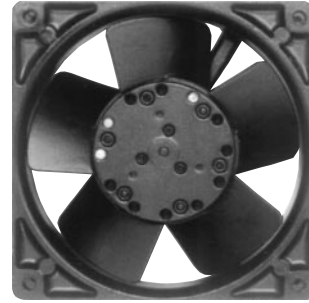

Performance Curve

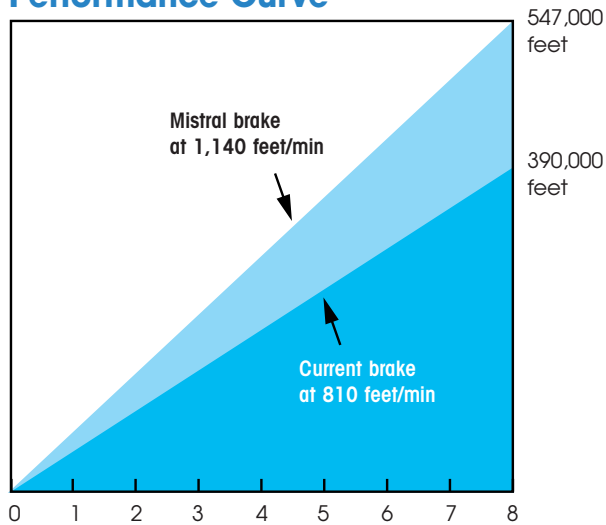

Fan Data and Connection Data

Model	Fan Voltages	Fan Power	Electric	Pneum.
200	220VAC or/order	20W	M16	1/8 BSP
	110VAC or/order		PG9	1/8 BSP
	24VDC		3/8 NPT	1/8 NPT
280	220VAC or/order	18W	M16	1/8 BSP
	110VAC or/order		PG9	1/8 BSP
	24VDC		3/8 NPT	1/8 NPT

Model	Dynamic Slipping Torque Capacity				Heat Transfer Capacity				Maximum Speed (rev./min.)	Inertia of Rotating Parts		Weight				Fan Power Rating (W)
	Air Pressure (lb.in.)		(Nm)		Continuous Operation		:30 On/:30 Off Operation			Wr ²	J=mr ²	Total Brake		Rotating Parts		
	min.* 3 psi	max. 80 psi	min.* 0.2 BAR	max. 5.5 BAR	(hp)	(kW)	(hp)	(kW)		(lb.ft. ²)	(kgm ²)	(lb.)	(kg)	(lb.)	(kg)	
Mistral																
200/2/LC	35	1770	4	200	3.2	2.4	3.5	2.6	2860	0.40	0.017	77	35	9.92	4.5	20
200/2	45	2655	5	300	3.2	2.4	3.5	2.6	2860	0.40	0.017	77	35	9.92	4.5	20
200/4/LC	35*	3540	4*	400	3.2	2.4	3.5	2.6	2860	0.40	0.017	77	35	9.92	4.5	20
200/4	45*	5310	5*	600	3.2	2.4	3.5	2.6	2860	0.40	0.017	77	35	9.92	4.5	20
200/6/LC	35*	5310	4*	600	3.2	2.4	3.5	2.6	2860	0.40	0.017	77	35	9.92	4.5	20
200/6	45*	7965	5*	900	3.2	2.4	3.5	2.6	2860	0.40	0.017	77	35	9.92	4.5	20
280/3/LC	45	3540	5	400	6.4	4.8	7	5.2	2090	1.80	0.076	110	50	20.72	9.4	25
280/3	55	5310	6	600	6.4	4.8	7	5.2	2090	1.80	0.076	110	50	20.72	9.4	25
280/6/LC	45*	7080	5*	800	6.4	4.8	7	5.2	2090	1.80	0.076	110	50	20.72	9.4	25
280/6	55*	10620	6*	1200	6.4	4.8	7	5.2	2090	1.80	0.076	110	50	20.72	9.4	25
280/9/LC	45*	10620	5*	1200	6.4	4.8	7	5.2	2090	1.80	0.076	110	50	20.72	9.4	25
280/9	55*	15930	6*	1800	6.4	4.8	7	5.2	2090	1.80	0.076	110	50	20.72	9.4	25

* With only one set of actuators engaged

Mistral Brakes

Selecting a Mistral Brake for a Corrugator Tension – unwind application

To properly select a tension brake for an unwind application the following information is needed.

Application Data

Max. Roll Dia. 48 in.
 Max. Web Width 36 in.
 Max. Web Speed 1200 fpm
 Max. Tension 2 pli
 Shaft Size 2 in.
 Min. Roll Dia. 6 in.
 Min. Web Width. 36 in.
 Min. Web Speed. 1000 fpm
 Min. Tension 1 pli
 Air Pressure Available. 80 psi

Calculations

Using the calculations below, consult Specifications Chart, page 95.

The brake selected for this application is a Mistral 200/2 with 2 1/4 inch bore.

$$\begin{aligned} \text{Max. Tension} &= \text{Max pli} \times \text{Max. Web Width} \\ &= 2 \times 36 = 72 \text{ lbs.} \end{aligned}$$

$$\begin{aligned} \text{Max. Torque} &= \frac{\text{Max. Tension} \times \text{Max. Roll Dia.}}{2} \\ &= \frac{72 \times 48}{2} = 1,728 \text{ lb.in.} \end{aligned}$$

$$\begin{aligned} \text{Max. rpm} &= \frac{\text{Max. Web Speed} \times 3.82}{\text{Min. Roll Dia.}} \\ &= \frac{1,200 \times 3.82}{6} = 764 \text{ rpm} \end{aligned}$$

$$\begin{aligned} \text{Heat H.P.} &= \frac{\text{Max. Tension} \times \text{Max Web Speed}}{33,000} \\ &= \frac{72 \times 1200}{33,000} = 2.6 \text{ Heat HP} \end{aligned}$$

$$\begin{aligned} \text{Min. Tension} &= \text{Min. pli} \times \text{Min. Web Width} \\ &= 1 \times 36 = 36 \text{ lbs.} \end{aligned}$$

$$\begin{aligned} \text{Min. Torque} &= \frac{\text{Min. Tension} \times \text{Min. Roll Dia.}}{2} \\ &= \frac{36 \times 6}{2} = 108 \text{ lb.in.} \end{aligned}$$

$$\begin{aligned} \text{Min. rpm} &= \frac{\text{Min. Web Speed} \times 3.82}{\text{Max. Roll Dia.}} \\ &= \frac{1000 \times 3.82}{48} = 80 \text{ rpm} \end{aligned}$$

How to Select

1. Check the required torque versus the available actuators' torque capacities. The Mistral 200/2/LC has a torque capacity of 1,180 lb.in. at 80 psi. The torque requirement is 1,728 lb.in. and therefore the Mistral 200/2/LC has insufficient torque capacity. However the 200/2 has sufficient torque capacity.
2. Check thermal requirement. The requirement is 2.6 heat HP. All the Mistral 200's are capable of 3.2 heat HP.
3. Check Maximum Bore. The requirement is 2.00 in. The Mistral 200's maximum bore is 2.25 inches.
4. Check Maximum rpm. The requirement is 764 rpm. The maximum rpm for the Mistral 200's is 2,860 rpm.

$$\begin{aligned} \text{Max. Air Pressure Required} &= \frac{\text{Max. Torque} \times 80 \text{ psi}}{\text{Catalog Torque Rating}} \\ &= \frac{1,728 \times 80}{1,770} = 78 \text{ psi} \end{aligned}$$

$$\begin{aligned} \text{Min. Air Pressure Required} &= \frac{\text{Min. Torque} \times 80 \text{ psi}}{\text{Catalog Torque Rating}} \\ &= \frac{108 \times 80}{1770} \\ &= 5 \text{ psi} \end{aligned}$$

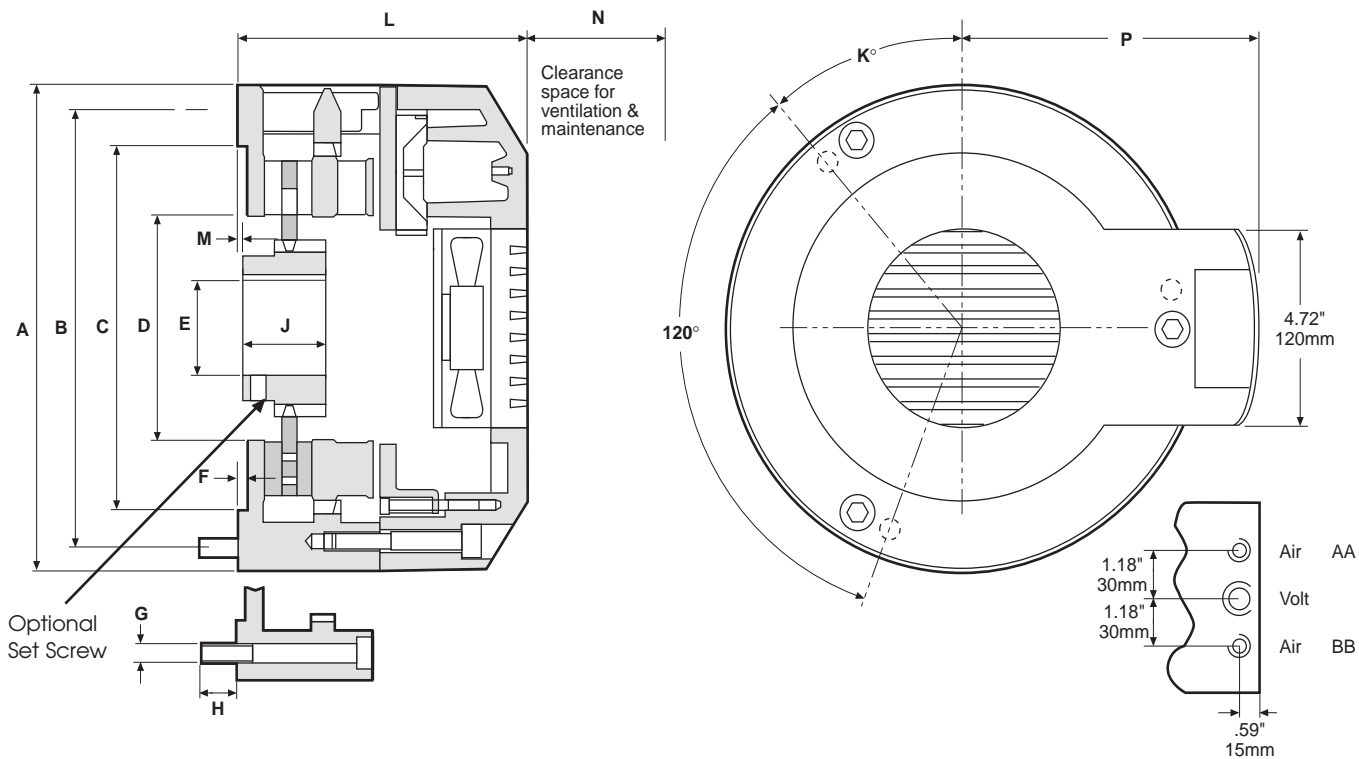

Dimensions (mm)

Model	A	B	F	G	H	J	K	L	M	N	P
		H.C.					DEG				
200	11.61 (295)	10.236 (260)	.24 (6)	1/2 (M12)	.98 (25)	1.97 (50)	40° (40°)	7.01 (178)	N/A (N/A)	2.76 (70)	7.19 (182.5)
280	16.14 (410)	13.976 (355)	0	5/8 (M16)	1.18 (30)	2.36 (60)	20° (20°)	7.56 (192)	0.37 (9.5)	3.15 (80)	9.47 (240.5)

Pilot Mounting Dimensions "C" and "D" (mm)		
Model	Mounting Pilot	Mounting Bolts Qty. and Size
Dim. "C"		
200	8.661 +.003/-0.000 (220 +.08/-0.00)	3 @ 1/2 - 13 UNC (3 @ M12 x 1-3/4)
Dim. "D"		
280	6.890 +.003/-0.000 (175 +.08/-0.00)	3 @ 5/8 - 11 UNC (3 @ M16 x 2)

Actuator/Inlet				
Model	No. of Actuators	No. of Air Inlets	No. of Actuators Per Air Inlets	
			AA	BB
200/2	2	2	2	0
200/4	4	2	2	2
200/6	6	2	2	4
280/3	3	2	3	0
280/6	6	2	3	3
280/9	9	2	3	6

Bore and Keyway Dimension "E" (mm)			
Model	Minimum Bore (No Keyway)	Maximum Bore with Keyway	
200	1.00 (25)	2 3/8 (60)	5/8 x 7/32 (18 x 4.4)
280	1.00 (25)	2 5/8 (65)	3/4 x 1/4 (18 x 4.4)

Note: For mounting, use socket head cap screws conforming to the ASTM-574-97a or ASTM-574M-97a (Metric Version).